

# PRODUCT INFORMATION PACKET



Model No: 191205.00

Catalog No: 191205.00

SST Duck™ General Purpose Motor, 0.50 & 0.33 HP, 3 Ph, 60 & 50 Hz, 230/460 & 190/380 V,  
1800 & 1500 RPM, 56C Frame, TENV

**Operational at 208-230/460 V @60HZ**



Regal and Leeson are trademarks of Regal Rexnord Corporation or one of its affiliated companies.  
©2023 Regal Rexnord Corporation, All Rights Reserved. MC017097E





### Nameplate Specifications

Phase	<b>3</b>	Output HP	<b>0.50 &amp; 0.33 Hp</b>
Output KW	<b>0.37 &amp; 0.25 kW</b>	Voltage	<b>230/460 &amp; 190/380 V</b>
Speed	<b>1740 &amp; 1440 rpm</b>	Service Factor	<b>1.15 &amp; 1.15</b>
Frame	<b>56C</b>	Enclosure	<b>Totally Enclosed Non Ventilated</b>
Thermal Protection	<b>No Protection</b>	Efficiency	<b>81.5 &amp; 78.5 %</b>
Ambient Temperature	<b>40 °C</b>	Frequency	<b>60 &amp; 50 Hz</b>
Current	<b>1.6/.8 &amp; 1.6/.8 A</b>	Power Factor	<b>68</b>
Duty	<b>Continuous</b>	Insulation Class	<b>F</b>
Design Code	<b>B</b>	KVA Code	<b>L</b>
Drive End Bearing Size	<b>6205</b>	Opp Drive End Bearing Size	<b>6205</b>
UL	<b>Recognized</b>	CSA	<b>Y</b>
CE	<b>Y</b>	IP Code	<b>55</b>
Number of Speeds	<b>1</b>		

### Technical Specifications

Electrical Type	<b>Squirrel Cage Inverter Rated</b>	Starting Method	<b>Line Or Inverter</b>
Poles	<b>4</b>	Rotation	<b>Reversible</b>
Resistance Main	<b>29 Ohms</b>	Mounting	<b>Round</b>
Motor Orientation	<b>Horizontal</b>	Drive End Bearing	<b>Ball</b>
Opp Drive End Bearing	<b>Ball</b>	Frame Material	<b>Stainless Steel</b>
Shaft Type	<b>NEMA 56</b>	Overall Length	<b>9.78 in</b>
Frame Length	<b>9.72 in</b>	Shaft Diameter	<b>0.625 in</b>
Shaft Extension	<b>1.88 in</b>	Assembly/Box Mounting	<b>F1 ONLY</b>
Inverter Load	<b>CONSTANT 10:1</b>		
Connection Drawing	<b>005010.01</b>	Outline Drawing	<b>16993000</b>

This is an uncontrolled document once printed or downloaded and is subject to change without notice. Date Created:10/13/2023

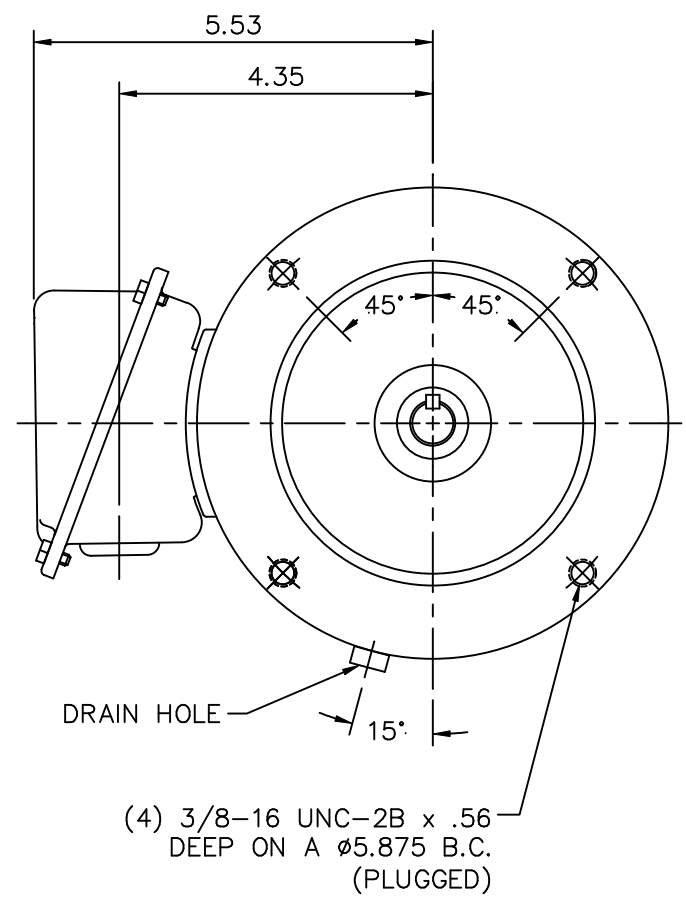
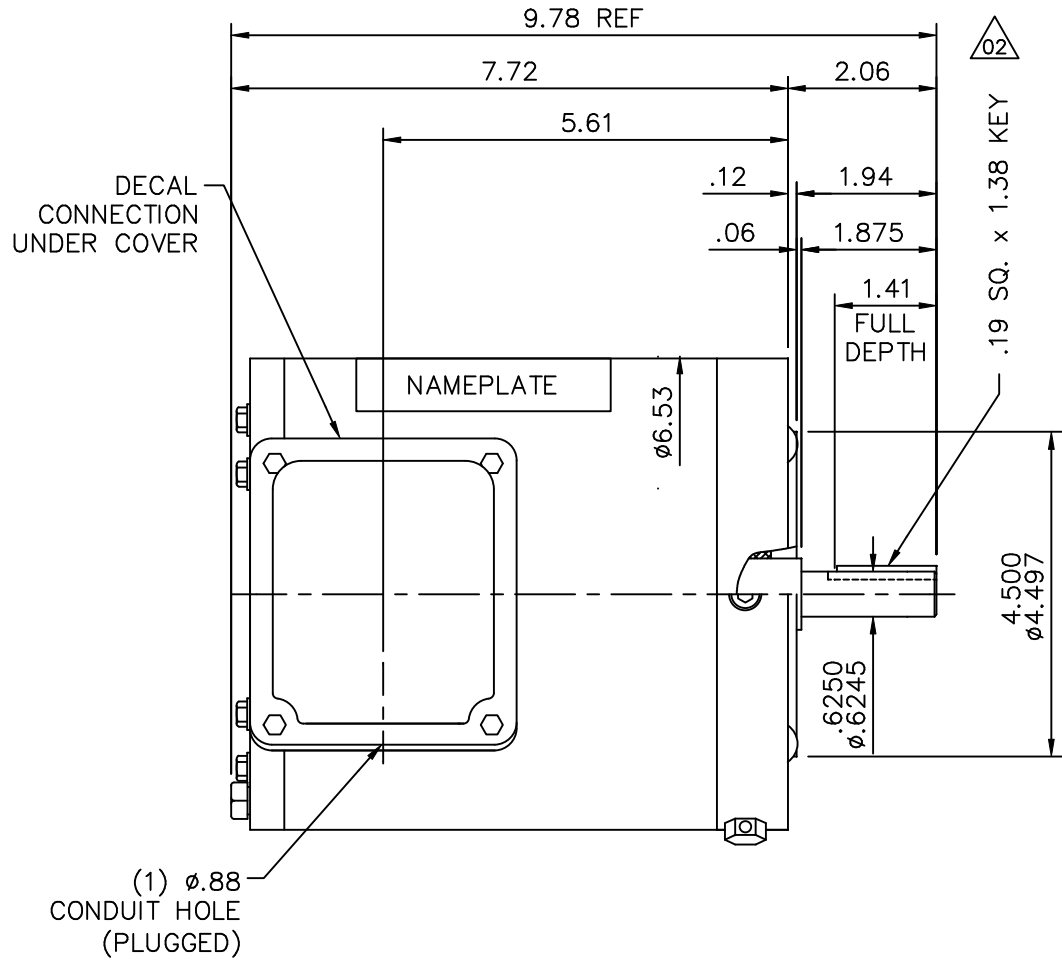

MAXIMUM FACE RUNOUT TO BE .004 T.I.R.  
 MAXIMUM PILOT ECCENTRICITY .004 T.I.R.  
 PERMISSIBLE SHAFT RUNOUT .002 T.I.R.

GASKETS THROUGHOUT

				TOLERANCES UNLESS SPECIFIED		 ELECTRIC MOTORS GEARMOTORS AND DRIVES	DRAWN MGM 04/10/03			
				DEC.	INCHES		CHK	RDW 04/10/03		
				.X	±.1					
				.XX	±.03	TITLE	OUTLINE - 56C FRAME TENV - "C" FACE	APPD	SCALE 3=8	
02	UPDATED SHAFT EXT DIMS	RDW 4/26/04	SW	.XXX	±.005			REF		
01	CONDUIT HOLE WAS 1/2-14 NPT, DIM .157 WAS .12	SW 10/7/2003	RDW	.XXXX	±.0005	MAT'L.		FMF		
NO.	REVISION	BY & DATE	CHK	ANG	±1/2"	FINISH		PREV		
THIS DRAWING IN DESIGN AND DETAIL IS OUR PROPERTY AND MUST NOT BE USED EXCEPT IN CONNECTION WITH OUR WORK ALL RIGHTS OF DESIGN AND INVENTION ARE RESERVED THIS IS AN ELECTRONICALLY GENERATED DOCUMENT - DO NOT SCALE THIS PRINT				RFP		CAD FILE	16993000	SIZE	DRAWING NO.	REV.
				DIST				A	169930.00	01

005010-01

VIEW FROM OUTSIDE OF MOTOR AT SWITCH END.

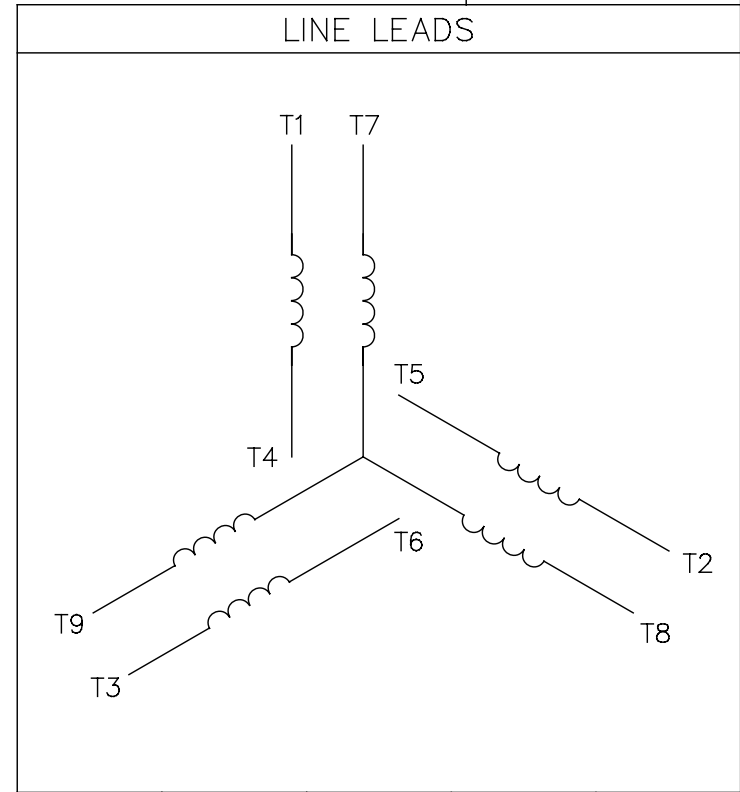
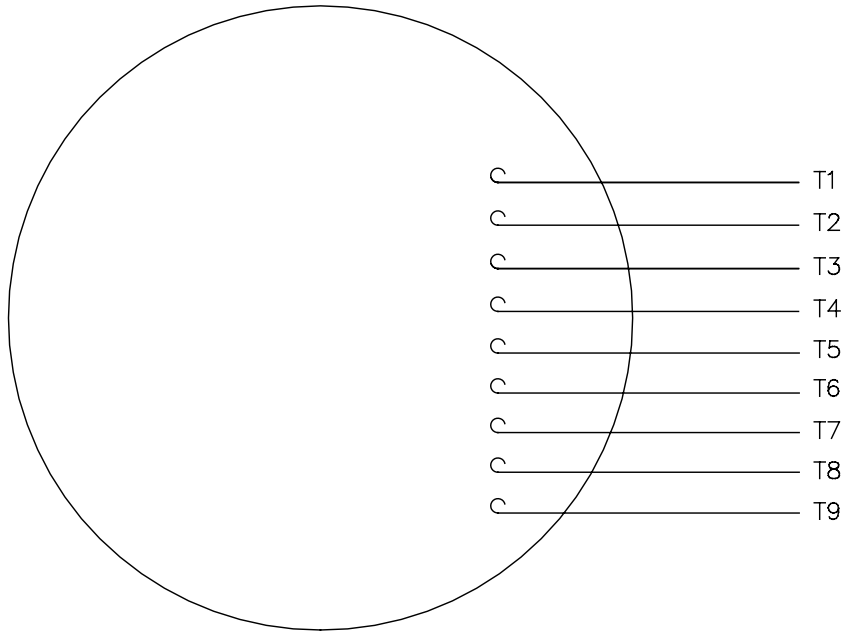

VOLTAGE	L1	L2	L3	JOIN & INSULATE
HIGH	T1	T2	T3	(T4,T7) (T5,T8) (T6,T9)
LOW	T1,T7	T2,T8	T3,T9	T4,T5,T6

				TOLERANCES UNLESS SPECIFIED		<b>REGAL</b> ™ Regal Beloit America, Inc.		DRAWN RDW 04/12/02			
				DEC.	INCHES			CHK			
				.X	±.1			APPD			
				.XX	±.01			SCALE 1=1			
				.XXX	±.005	TITLE		REF FIG.2-51			
A	UPDATED TO REGAL LOGO	SAJ 06/26/15	AJY	.XXXX	±.0005	MAT'L		FMF			
NO.	REVISION	BY & DATE	CHK	ANG	±1/2"	FINISH		PREV			
THIS DRAWING IN DESIGN AND DETAIL IS OUR PROPERTY AND MUST NOT BE USED EXCEPT IN CONNECTION WITH OUR WORK ALL RIGHTS OF DESIGN AND INVENTION ARE RESERVED THIS IS AN ELECTRONICALLY GENERATED DOCUMENT - DO NOT SCALE THIS PRINT				RFP	04/12/02	CAD FILE		00501001	SIZE	DRAWING NO.	REV.
				DIST	BRF-NLV			A	005010-01	A	



CERTIFICATION DATA SHEET

1051 CHEYENNE AVE.  
GRAFTON, WI 53024  
PH. 262-377-8810

CATALOG #: 191205.00

CONN. DIAGRAM: 005010.01

OUTLINE: 16993000

MOUNTING: F1 ONLY

WINDING #: QT6348 NR 3 A

TYPICAL MOTOR PERFORMANCE DATA

HP	kW	SYNC. RPM	F.L. RPM	FRAME	ENCLOSURE	KVA CODE	DESIGN
1/2&1/3	0.37&0.25	1800	1740&1440	56C	TENV	L	B

PH	Hz	VOLTS	AMPS	START TYPE	DUTY	INSL	S.F.	AMB°C
3	60/50	208-230/460&190/380	1.5-1.6/.8&1.6/.8	ACROSS THE LINE	CONTINUOUS	F3	1.15/1.15	40

FULL LOAD EFF:	81.5	3/4 LOAD EFF:	79.9	1/2 LOAD EFF:	75.4	GTD. EFF		ELEC. TYPE	
FULL LOAD PF:	68	3/4 LOAD PF:	59.1	1/2 LOAD PF:	46.3	-		SQ CAGE IND RUN	

F.L. TORQUE	LOCKED ROTOR AMPS	L.R. TORQUE	B.D. TORQUE	F.L. RISE°C
24 OZ-FT	12 / 6	70.5 OZ-FT 294 %	89 OZ-FT 371 %	-

SOUND PRESSURE @ 3 FT.	SOUND POWER	ROTOR WK^2	MAX. WK^2	SAFE STALL TIME	STARTS / HOUR	APPROX. MOTOR WGT
- dBA	- dBA	-1 LB-FT^2	- LB-FT^2	- SEC.	-	- LBS.

\*\*\* SUPPLEMENTAL INFORMATION \*\*\*

DE BRACKET TYPE	ODE BRACKET TYPE	MOUNT TYPE	ORIENTATION	SEVERE DUTY	HAZARDOUS LOCATION	DRIP COVER	SCREENS	PAINT
C-FACE	STANDARD	ROUND	HORIZONTAL	FALSE	NONE	FALSE	NONE	NO PAINT

BEARINGS		GREASE	SHAFT TYPE	SPECIAL DE	SPECIAL ODE	SHAFT MATERIAL	FRAME MATERIAL
DE	ODE						
BALL	BALL	POLYREX EM	STANDARD 56	NONE	NONE	1045 HOT ROLLED (C-204)	STAINLESS STEEL
6205	6205						

THERMO-PROTECTORS				THERMISTORS	CONTROL	SPACE HEATERS
THERMOSTATS	PROTECTORS	WDG RTDs	BRG RTDs			
NONE	NOT	NONE	NONE	NONE	FALSE	NONE VOLTS

\*  
N  
O  
T  
E  
S

<b>INVERTER TORQUE:</b> NONE
<b>INV. HP SPEED RANGE:</b> NONE
<b>ENCODER:</b> NONE
NONE NONE
NONE NONE PPR
<b>BRAKE:</b> NONE NONE
NONE P/N NONE
NONE NONE
NONE FT-LB NONE V NONE Hz

Data Sheet

Date: 1/22/2018

191205.00



Data @ 460 V

Motor Load Data

Load	0%	25%	50%	75%	100%	115%	125%	LR
Current (Amps)	0.60	0.62	0.68	0.75	0.80	0.88	0.95	6.0
Torque (ft-lb)	0.00	96.1	192	288	384	6,923	480	1,129
RPM	1800	1788	1776	1765	1752	1,746	1738	0
Efficiency (%)		63.5	75.4	79.9	81.7	81.9	82.1	
P.F. (%)	11.9	30.4	46.3	59.1	71.7	73.1	74.5	0.0

Motor Speed Data

	LR	Pull-Up	BD	Rated	Idle
Speed (RPM)	0	900	1656	1752	1800
Current (Amps)	6.0	5.5	3.6	0.80	0.60
Torque (ft-lb)	1,129	913	1,425	384	0.00

Information Block				
HP	0.5			
Sync. RPM	1800			
Frame	0			
Enclosure	TENV			
Construction	NA			
Voltage	208-230/460#190/380 V			
Frequency	60 Hz			
Design	B			
LR Code letter	L			
Service Factor	1.15			
Temp Rise @ FL	73 °C			
Duty	CONT			
Ambient	40 °C			
Elevation	1,000 feet			
Rotor/Shaft wk <sup>2</sup>	-1.00 Lb-Ft <sup>2</sup>			
Ref Wdg	QT6348 NR			
Sound Pressure @ 1M	999 dBA			
VFD Rating	NONE			
Outline Dwg	16993000			
Conn. Diag	005010.01			
Additional Specifications:				
0				
0				
EQUIV CKT (OHMS / PHASE)				
R1	R2	X1	X2	Xm
0.0000	0.0000	0.0000	0.0000	0.0000

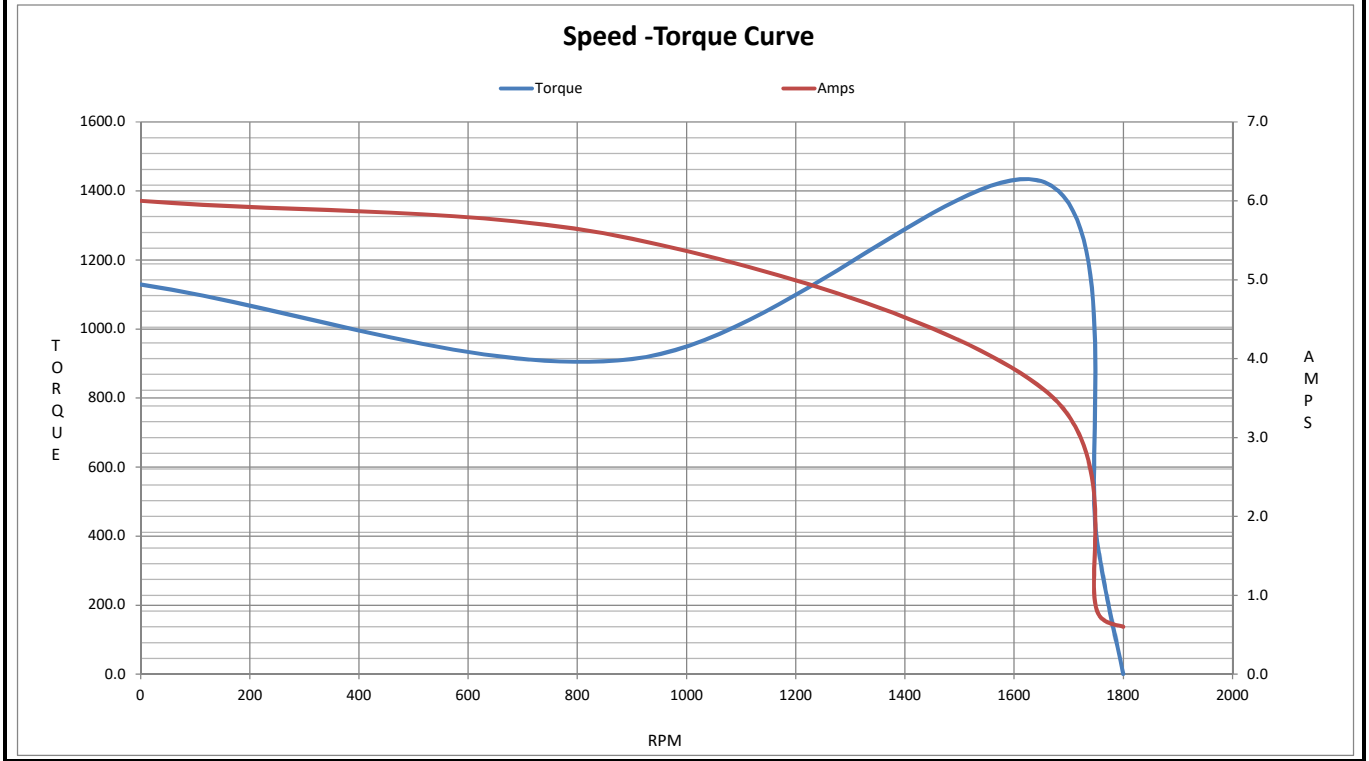
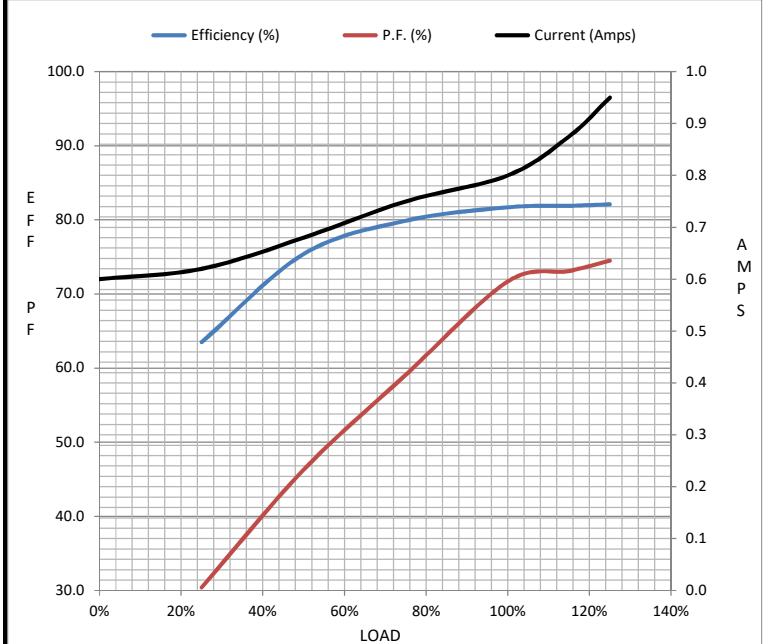

## EC Declaration of Conformity

The undersigned representing  
the manufacturer:

Regal Beloit America  
100 East Randolph St.  
Wausau, WI 54401

and the authorized representative  
established within the Community:

Marathon Electric UK  
6F Thistleton Road Ind. Estate  
Market Overton  
Oakham, Rutland LE15 7PP UK

are committed to providing customers with products that comply with applicable regulations and international protocols to which they are subject, including the requirements of the European Parliament Directive on the Harmonization of the laws relating to electrical equipment designed for use within certain voltage limits (2014/35/EU).

Regal Beloit America declares that the following product(s), to which this declaration relates, are in conformity with the relevant sections of the EC standards listed below.

This statement supersedes any statements previously issued pertaining to the product(s) listed below and is subject to change without notice.

Model No : 191205.00

(Model No. may contain prefix and/or suffix characters)

Catalog No : 191205.00

Rework No : N/A

Directives :

Low Voltage Directive 2014/35/EU

Harmonized Standards Used :

EN 60034-1: 2010 (IEC 60034-1: 2010)

EN 60034-5: 2001/A1:2007 (IEC 60034-5: 2000/A1:2006)

Authorized Representative:

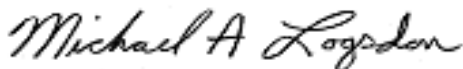

Michael A. Logsdon  
Vice President, Technology

Authorized Representative in the Community:



Julian Clark  
Marketing Engineer

Created on 09/01/2022

**CE 22**